

LUBRICATION SYSTEM

INDEX	D- 2
OUTLINE	D- 3
SPECIFICATIONS.....	D- 3
TROUBLESHOOTING GUIDE	D- 3
INSPECTION	D- 4
PREPARATION	D- 4
ENGINE OIL.....	D- 4
OIL PRESSURE	D- 4
ENGINE OIL	D- 4
REPLACEMENT.....	D- 4
OIL FILTER	D- 5
REPLACEMENT.....	D- 5
OIL COOLER	D- 5
REMOVAL / INSTALLATION	D- 5
OIL PAN	D- 6
REMOVAL	D- 6
INSPECTION	D- 7
INSTALLATION.....	D- 7
OIL PUMP	D- 8
PREPARATION	D- 8
REMOVAL	D- 8
DISASSEMBLY	D- 9
INSPECTION	D- 9
ASSEMBLY	D-10
INSTALLATION.....	D-10

06U0DX-001

INDEX

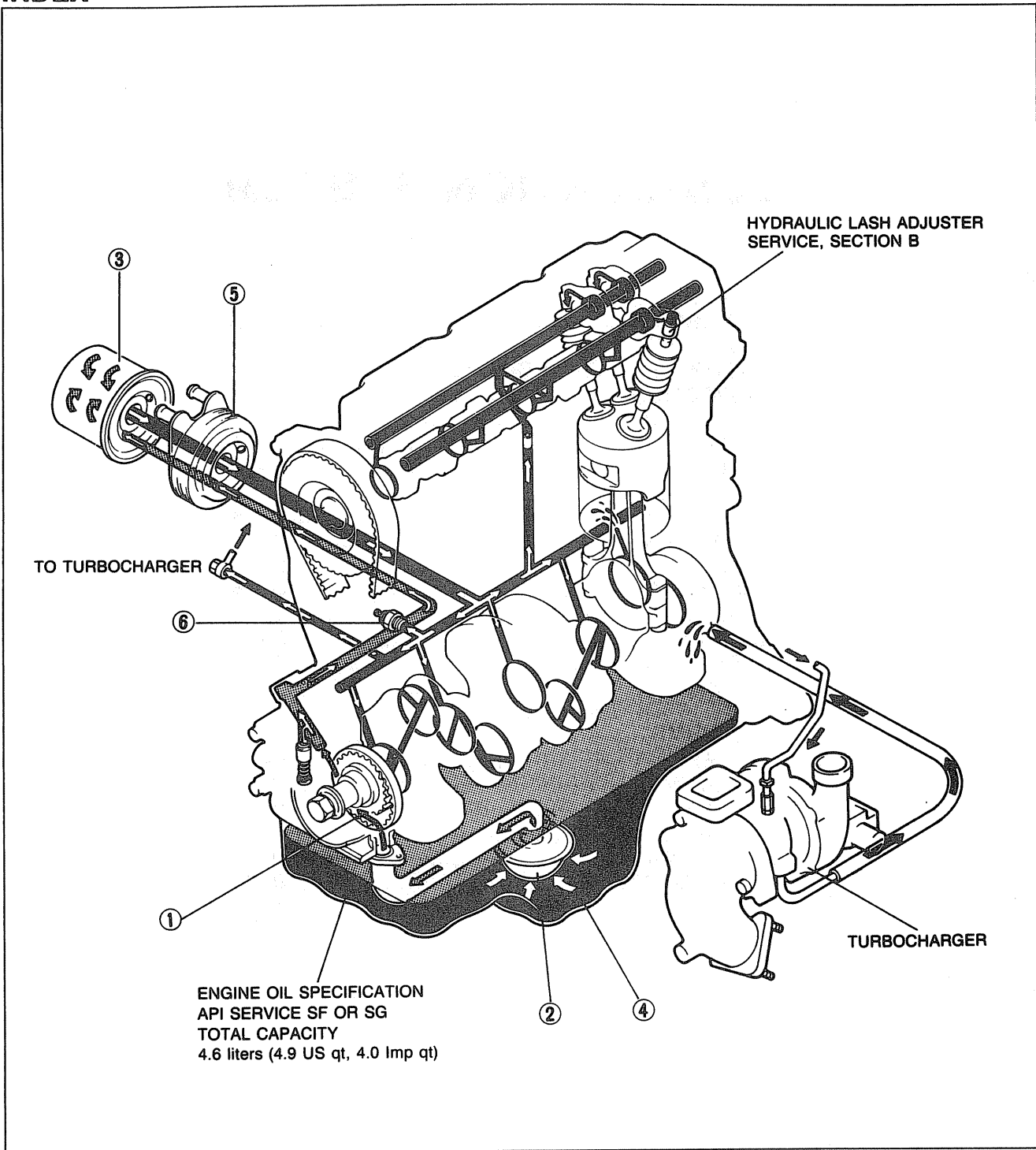

ENGINE OIL SPECIFICATION
 API SERVICE SF OR SG
 TOTAL CAPACITY
 4.6 liters (4.9 US qt, 4.0 Imp qt)

06U0DX-002

1. Oil pump		4. Oil pan	
Removal	page D- 8	Removal	page D- 6
Installation	page D-10	Installation	page D- 7
Disassembly	page D- 9	5. Oil cooler (Turbo)	
Assembly.....	page D-10	Removal / Installation.....	page D- 5
Inspection.....	page D- 9	6. Oil pressure	
2. Oil strainer		Inspection.....	page D- 4
Removal / Installation.....	page D- 6	7. Engine oil	
3. Oil filter		Inspection.....	page D- 4
Replacement	page D- 5	Replacement	page D- 4

OUTLINE

SPECIFICATIONS

Item		Engine	F2	
			Turbo	Non-Turbo
Lubrication system			Force-fed	
Oil pump	Type		Trochoid gear	
	Regulated pressure	kPa (kg/cm ² , psi)	294—392 (3.0—4.0, 43—57)	
	Oil pressure	kPa (kg/cm ² , psi)—rpm	147—245 (1.5—2.5, 21—36)—1,000 294—392 (3.0—4.0, 43—57)—3,000	
Oil filter	Type		Full-flow, paper element	
	Relief pressure differential	kPa (kg/cm ² , psi)	78—118 (0.8—1.2, 11—17)	
Oil cooler	Type		Water-cooled, 4-stage	—
Oil warning pressure		kPa (kg/cm ² , psi)	29 (0.3, 4.3)	
Oil capacity	Total (dry engine)	liters (US qt, Imp qt)	4.6 (4.9, 4.0)	
	Oil pan	liters (US qt, Imp qt)	3.9 (4.1, 3.4)	
	Oil filter	liters (US qt, Imp qt)	0.22 (0.23, 0.19)	
Engine oil (API service)			SF or SG	

16U0DX-001

Recommended SAE Viscosity

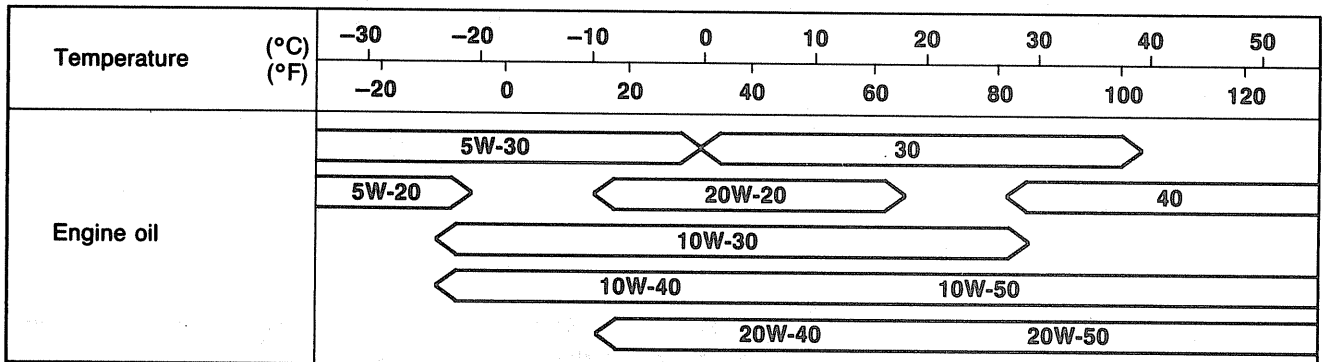

Temperature range anticipated before next oil change, °C(°F)

63G02D-303

TROUBLESHOOTING GUIDE

Problem	Possible Cause	Remedy	Page
Engine hard starting	Improper engine oil Insufficient engine oil	Replace Add oil	D- 4 D- 4
Excessive oil consumption	Oil working up or working down Oil leakage	Refer to Section B Repair	—
Oil pressure drop	Insufficient oil Oil leakage Worn or damaged oil pump gear (outer and inner rotor) Worn plunger (inside oil pump) or weak spring Clogged oil strainer Excessive main bearing or connecting rod bearing clearance	Add oil Repair Replace Replace Clean Refer to Section B	D- 4 — D- 9 D- 9 —
Warning lamp illuminated while engine running	Oil pressure drop Malfunction of oil pressure switch Malfunction of electrical system	As described above Refer to Section T Refer to Section T	—

06U0DX-004

INSPECTION

PREPARATION
SST

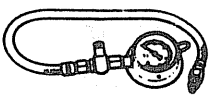
49 0187 280 Oil-pressure gauge		For inspection of oil pressure
-----------------------------------	---	--------------------------------

06U0DX-005

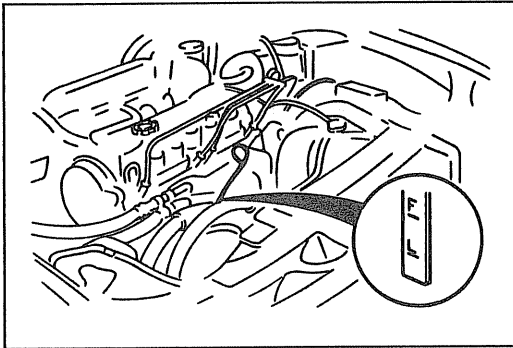

06U0DX-006

ENGINE OIL

1. Be sure the vehicle is on level ground.
2. Warm up the engine to normal operating temperature and stop it.
3. Wait for five minutes.
4. Remove the oil level gauge and check the oil level and condition.
5. Add or replace oil if necessary.

Note

- The distance between the L and F marks on the level gauge represents 1.0 liter (1.06 US qt, 0.88 Imp qt).

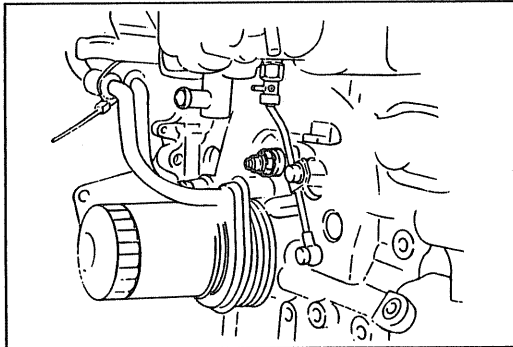

69G02A-006

OIL PRESSURE

1. Remove the oil pressure switch.

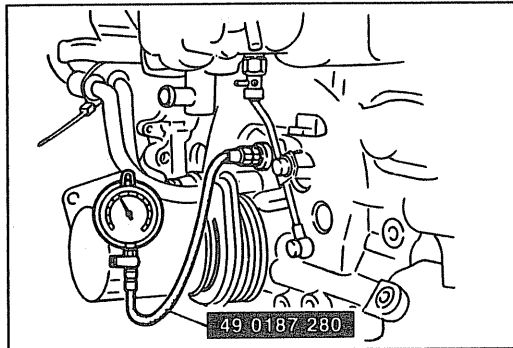

96U02X-002

2. Screw the **SST** into the pressure switch installation hole.
3. Warm up the engine to normal operating temperature.
4. Run the engine at 3,000 rpm, and note the gauge reading.

Oil pressure:

147—245 kPa

(1.5—2.5 kg/cm², 21—36 psi)—1,000 rpm

294—392 kPa

(3.0—4.0 kg/cm², 43—57 psi)—3,000 rpm

5. If the pressure is not as specified, check for the cause, and repair if necessary. (Refer to Troubleshooting Guide.)

ENGINE OIL

REPLACEMENT

1. Warm up the engine to the normal operating temperature and stop it.
2. Remove the oil filler cap and the oil pan drain plug.
3. Drain the oil into a suitable container.

Warning

- Be careful when draining, the oil is very hot.

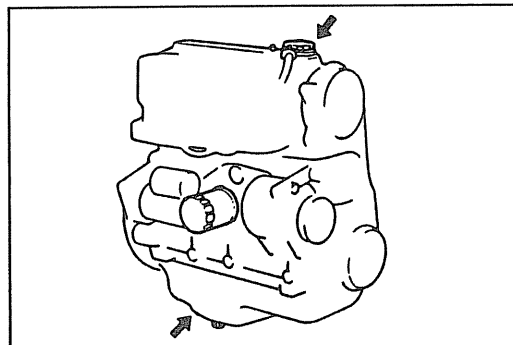

86U02X-006

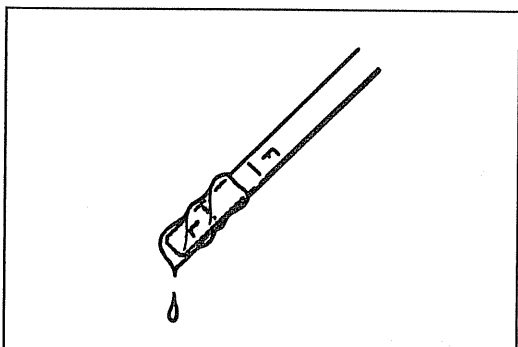

96U02X-003

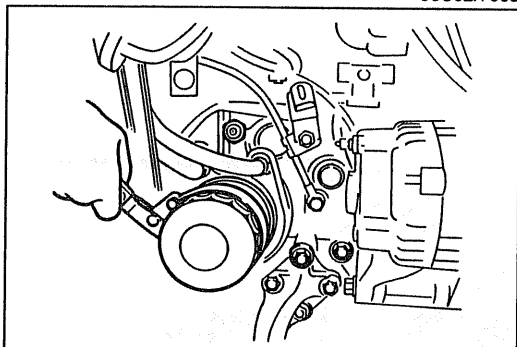

86U02X-008

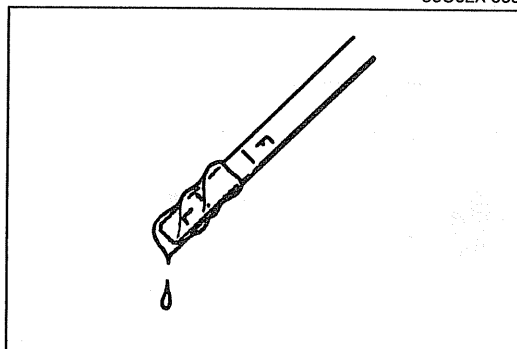

16U0DX-002

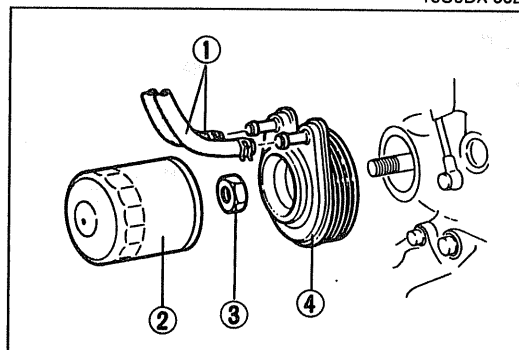

16U0DX-003

4. Install the drain plug and a new gasket.
5. Refill the engine with the specified type and amount of engine oil.
6. Refit the oil filler cap.

Oil pan capacity:
3.9 liters (4.1 US qt, 3.4 Imp qt)

7. Recheck the oil level after the engine has been run.

D

OIL FILTER

REPLACEMENT

1. Remove the oil filter with a suitable wrench.
2. Use a clean rag to wipe off the mounting surface on the engine.

3. Apply a small amount of engine oil to the rubber seal of the new filter.
4. Install the oil filter until the rubber seal contacts the base, and then tighten the filter 1-1/6 turn with a wrench.
5. Start the engine and inspect around the filter seal for leaks.
6. Check the oil level and add oil if necessary.

Oil filter capacity:
0.22 liters (0.23 US qt, 0.19 Imp qt)

OIL COOLER (Turbo)

REMOVAL / INSTALLATION

Remove in the sequence shown in the figure. Install in the reverse order of removal.

1. Water hose
2. Oil filter
3. Nut
4. Oil cooler

Nut tightening torque:
29—39 N·m (3.0—4.0 m·kg, 22—29 ft·lb)

OIL PAN

REMOVAL

1. Disconnect the negative battery cable.
2. Drain the engine oil.
3. Remove in the order shown in the figure, referring to **Removal Note**.

16U0DX-004

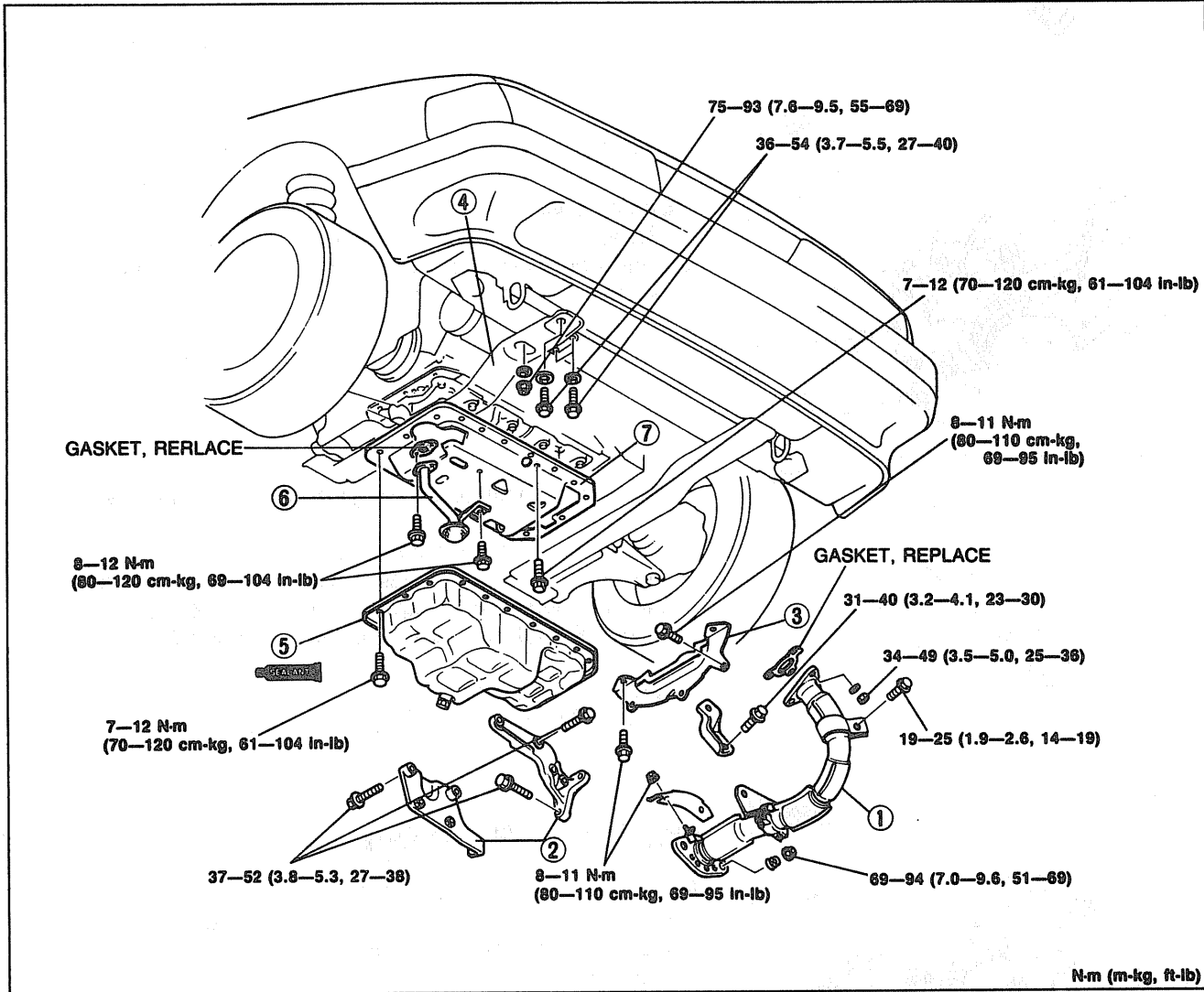

16U0DX-005

1. Exhaust pipe
2. Gusset plate
3. Clutch housing under cover
4. Sub frame (RH)

5. Oil pan
6. Oil strainer
7. Stiffener

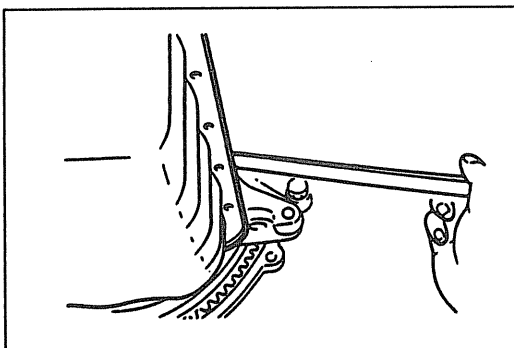

96U02X-006

Removal Note

Oil pan

1. Remove the oil pan mounting bolts.
2. Insert a scraper or a suitable tool between the oil pan and the stiffener to separate them.
3. Remove the oil pan.

Caution

- Do not bend the oil pan when prying loose.

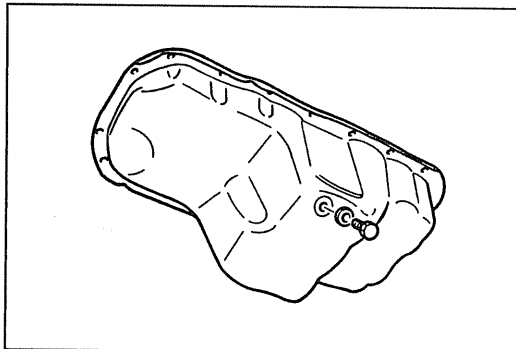

4BG02X-037

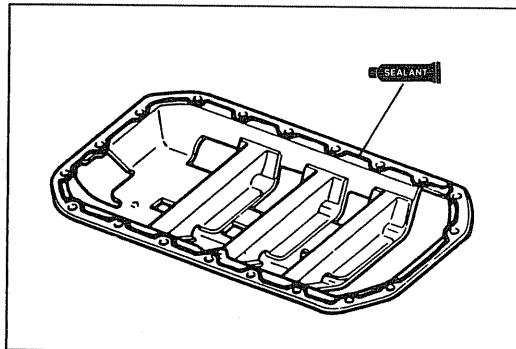

16U0DX-006

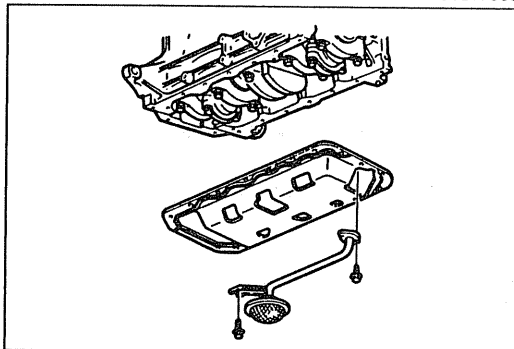

96U02X-008

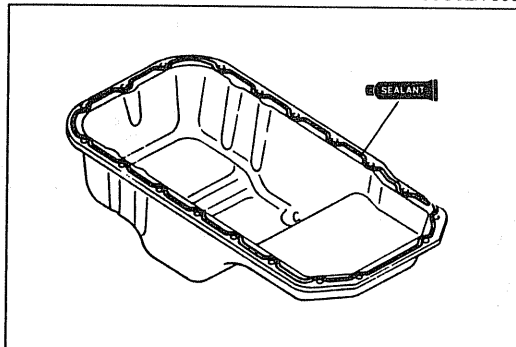

96U02X-009

INSPECTION

Check the following points. Repair or replace if necessary.

1. Cracks, deformation, damage
2. Damaged drain plug threads

INSTALLATION

Install in the reverse order of removal, referring to **Installation Note**.

Installation Note**Stiffener, oil strainer, oil pan**

1. Remove any dirt or other material from the contact surface.
2. Apply silicon sealant to the stiffener around the inside of the bolt holes and overlap the ends.
3. Install the stiffener.

Tightening torque:

7—12 N·m (70—120 cm·kg, 61—104 in·lb)

4. Install the oil strainer and a new gasket.

Tightening torque:

8—12 N·m (80—120 cm·kg, 69—104 in·lb)

5. Apply a continuous bead of silicon sealant to the oil pan around the inside of the bolt holes and overlap the ends.

Caution

- **Secure the stiffener and oil pan within 30 minutes after applying the sealant.**

6. Install the oil pan.

Tightening torque:

7—12 N·m (70—120 cm·kg, 61—104 in·lb)

Steps After Installation

1. Supply the specified amount and type of oil.
2. Start the engine and check for leakage.

D

OIL PUMP

OIL PUMP

PREPARATION

SST

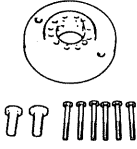
<p>49 S120 710</p> <p>Holder, coupling flange</p> 	<p>For removal and installation of timing belt pulley</p>	<p>49 H011 101A</p> <p>Lock tool, crankshaft</p> 	<p>For removal and installation of timing belt pulley</p>
---	---	--	---

06U0DX-008

REMOVAL

1. Disconnect the negative battery cable.
2. Drain the engine oil.
3. Remove in the order shown in the figure, referring to **Removal Note**.

16U0DX-007

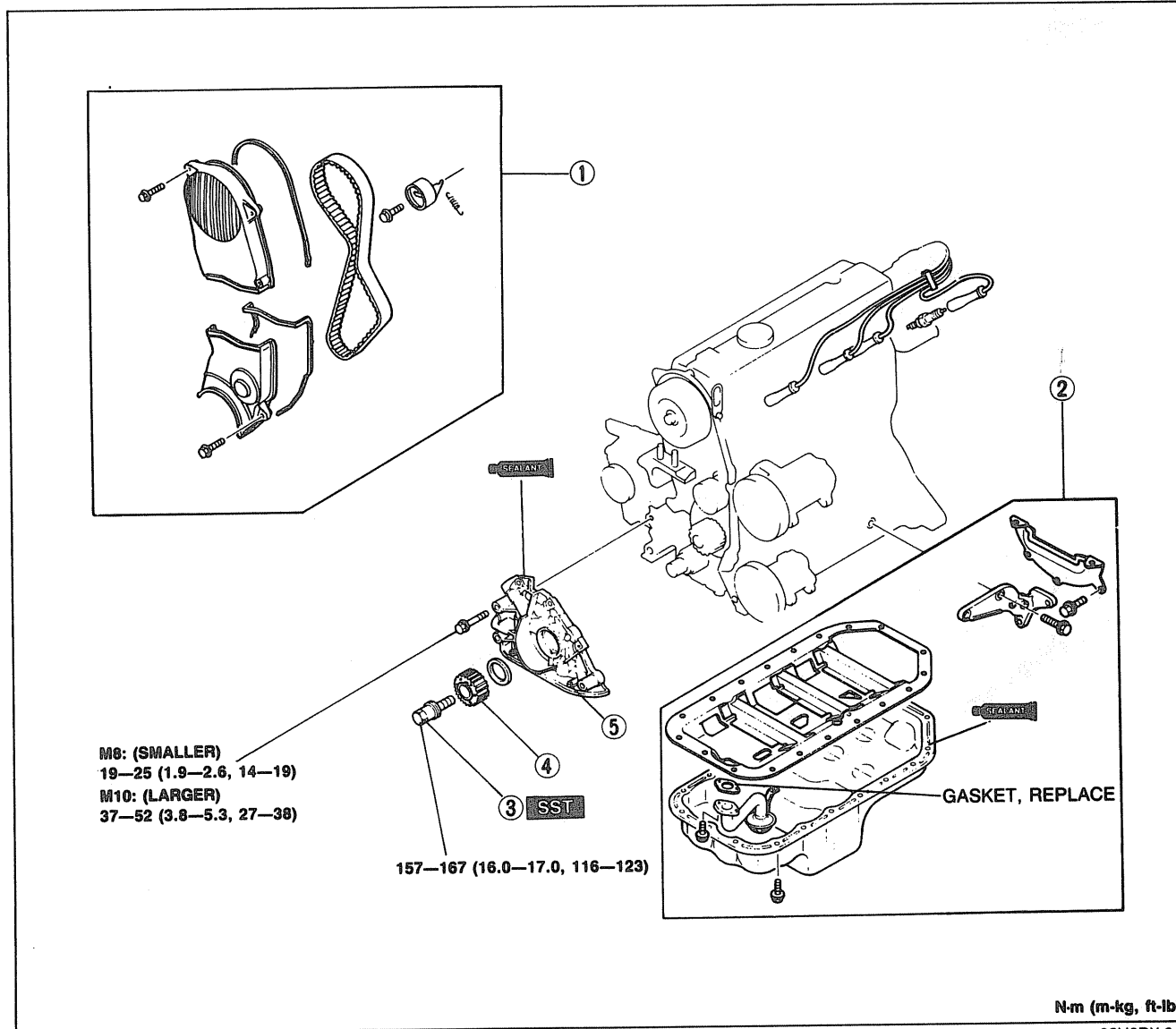

06U0DX-010

1. Timing belt (Refer to Section B)
2. Oil pan (Refer to page D-6)
3. Timing belt pulley lock bolt

4. Timing belt pulley
5. Oil pump

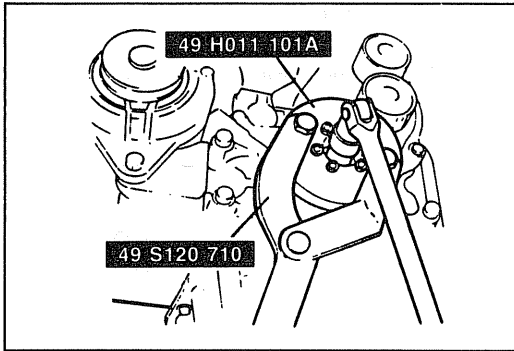

76G02A-026

Removal Note Timing belt pulley lock bolt

Hold the timing belt pulley with the **SST** and remove the lock bolt.

DISASSEMBLY

Disassemble in the order shown in the figure.

16U0DX-008

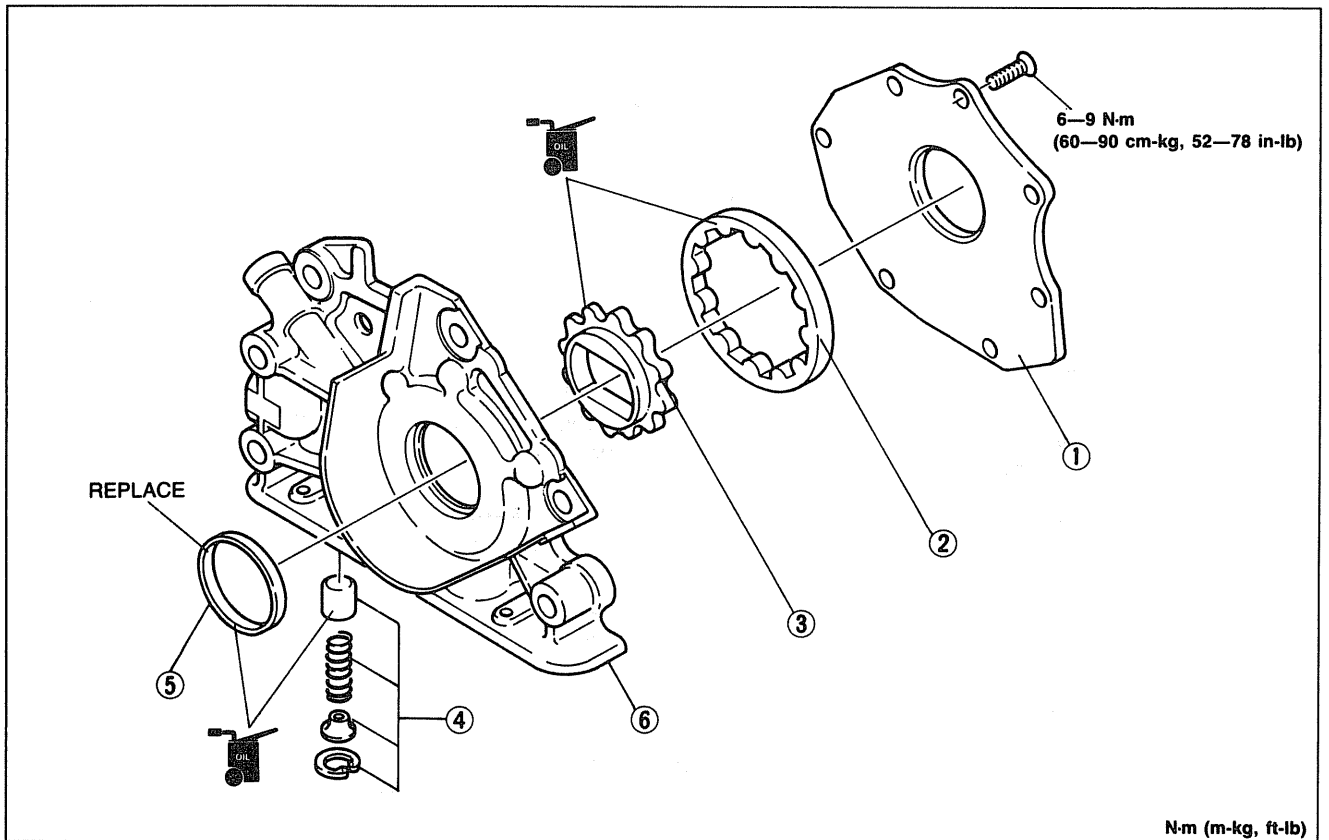

N-m (m-kg, ft-lb)

69G02B-013

1. Pump cover
2. Outer rotor
3. Inner rotor

4. Pressure relief valve
5. Oil seal
6. Oil pump body

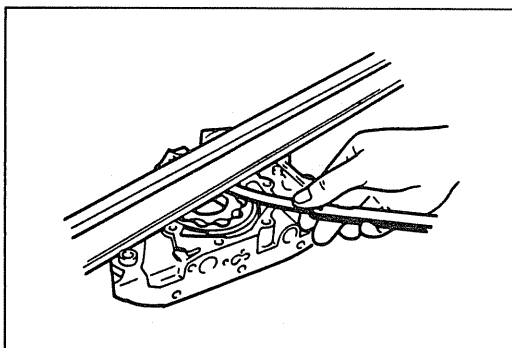

16U0DX-010

INSPECTION

1. Check for the following and repair or replace as necessary.
 - (1) Distorted or damaged oil pump body or cover
 - (2) Worn or damaged plunger
 - (3) Weak or broken plunger spring
2. Measure the side clearance.

Clearance: 0.10mm (0.004 in) max.

OIL PUMP

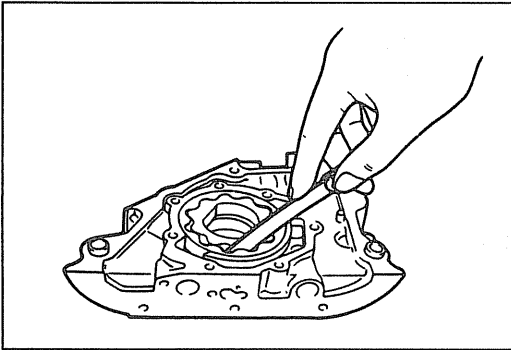

69G02B-015

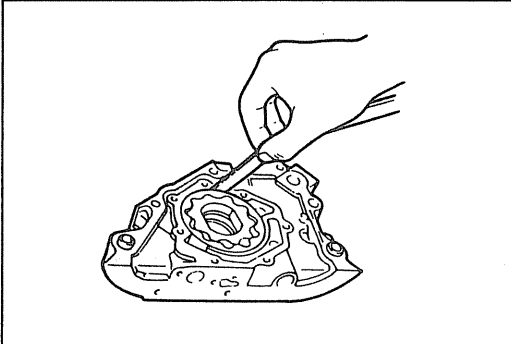

96U02X-014

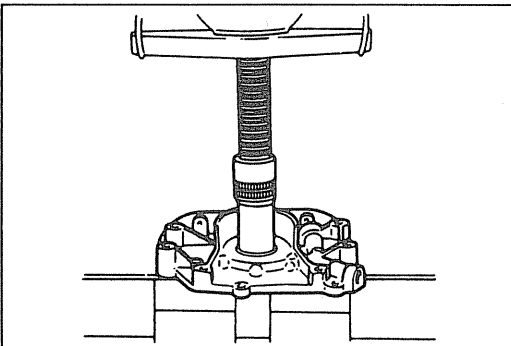

96U02X-016

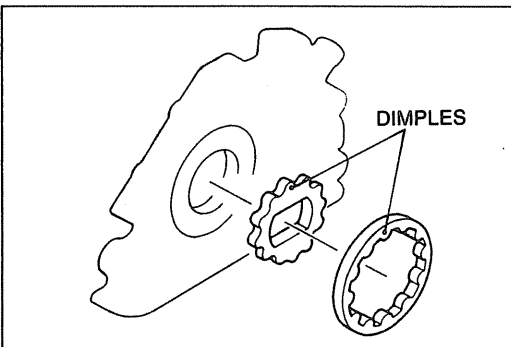

96U02X-015

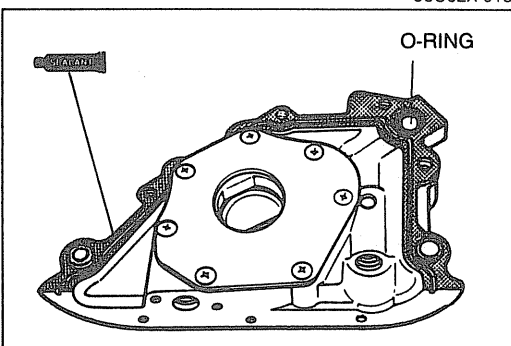

16U0DX-009

3. Measure the tooth tip clearance.

Clearance: 0.18mm (0.007 in) max.

4. Measure the outer rotor to pump body clearance.

Clearance: 0.20mm (0.008 in) max.

ASSEMBLY

Assemble the pump as follows.

Oil Seal

1. Apply engine oil to the pump body and the outside of the new oil seal.
2. Press in the oil seal with a suitable pipe (outer diameter: 48mm (1.89 in)).

Pressure Relief Valve

1. Install the plunger and spring in the pump body.
2. Fit the snap ring.

Outer and Inner Rotor

Install the rotors with the dimples facing the pump cover.

Oil Pump Cover

1. Apply thread locking compound to the cover mounting screws' threads.
2. Attach the oil pump cover to the body.

Tightening torque:

6—9 N·m (60—90 cm·kg, 52—78 in·lb)

3. Check that the rotor turns smoothly.

INSTALLATION

Install in the reverse order of removal, referring to **Installation Note**.

Installation Note**Oil pump**

1. Apply grease to a new O-ring and install it in the oil pump body.
2. Apply silicon sealant to the shaded area as shown in the figure.
3. Apply engine oil to the oil seal lip.

Steps After Installation

1. Supply the specified amount and type of oil.
2. Start the engine and check for leakage.